

Electromagnetic Field Shielding in Incubators

Seyed Amin Hashemi ¹, Afsane Bazzi ², Ahmad Cheldavi ³, Seyed Mehrdad Saviz ^{2,*} 

¹ Department of Electrical Engineering, Amirkabir University of Technology, Tehran, Iran

² Department of Biomedical Engineering, Amirkabir University of Technology, Tehran, Iran

³ Department of Electrical Engineering, Iran University of Sciences and Technology, Tehran, Iran

*Corresponding Author: Seyed Mehrdad Saviz
Email: msaviz@aut.ac.ir

Received: 08 July 2020 / Accepted: 27 September 2020

Abstract

Purpose: Cell experiments are vitally dependent on CO₂ incubators. The heating system of usual incubators result in undesirable induction of Electromagnetic (EM) fields on cells that result in decreased accuracy in bio-electromagnetic tests. EM shields can cause a considerable decrease in the stray fields and eliminate the undesirable induction.

Materials and Methods: CST-2019 is used for simulations. five different shielding systems have been examined in this paper. We try to modify shape and material used for shielding to achieve better result. (Iron, Mu-Metal, steel).

Results: We introduce a simple practical design, together with variations of previously reported ones, and numerical evaluation of their magnetic field attenuation.

Conclusion: The targeted design decreases the field within the shield to about 0.03 times of the incident magnetic field, while having holes for air and CO₂ exchange.

Keywords: Shielding; Incubator; Electromagnetics; Cell Culture; Protection; Bioelectromagnetics.

1. Introduction

Since the environmental temperature may affect physiological response in in-vitro biological experiments, it is necessary to provide cells with similar environment to that in the body; which is the reason why biological incubators are used. In general incubators adjust humidity, temperature, and air CO₂ based on cell culture [1, 2, 3, 4]. Almost all biological incubators use special heating elements to adjust the temperature. Unfortunately, these elements cause Electromagnetic (EM) pollution within the incubators. Since cell behavior is influenced by electromagnetic fields, these stray EM fields interrupt the accuracy of experiments, especially in the study of controlled EM fields' effects on cells [1, 2, 3].

Ambient magnetic fields exist on the earth (essentially constant such as earth's geomagnetic field, or time-variant produced by particular sources, especially man-made [4]). The earth's magnetic field (B) is, dependent on location, variable from 25 to 70 μT with small fluctuations around $\pm 0.1 \mu\text{T}$ [4, 5]. A typical house has a time-variant background magnetic field from 0.05 to 0.4 μT [4, 6], which is mostly around 50 Hz. Nevertheless, stray fields from incubators can be as large as 20 μT around 50 Hz.

Although these stray magnetic fields in the incubator have extremely low intensity, they can lead to resonant responses in cells, as some research show. Cellini *et al.* (2008) claimed that in the presence of 50Hz EM field, some bacterial responses such as modifying morphology from bacillary to coccoid as an immediate effect and some other effects appeared [7]. Some pieces of evidence have shown EM fields interfere with growth of cells, proliferation and differentiation, as demonstrated in murine and rat neuronal cells [8-13]. 50Hz EM fields cause an increase in the level of the anti-apoptotic protein BAG3 in melanoma cells [14]. Interestingly, the most intense induced EM field in incubators happens around 50Hz frequency (due to the power line frequency). All of these examples bring us to the fact that EM fields have considerable effects on cell incubation and tissues, so it is necessary to shield cell-samples in incubators to protect cells from undesirable induced effects.

For low-frequency EM fields, the materials such as multilayer ferromagnetic (Mu-metal or Permalloy) and also thick-walled eddy current shield have been

used [4, 15, 16]. Shielding that has been discussed in this paper should have three primary properties:

1. This shield must be able to eliminate whole interrupting fields, but since the main power of these fields are concentrated in range 50-60 Hz, proper attenuation is steep.
2. It must consist of some pores for airflow and displacement of an adequate amount of CO₂ and Humidity, which requires high accuracy in design for trade-off with the first property.
3. There should be no region in the shield that provides good areas for parasites to grow and spread, such as hinges, doors, or corners.

Some solutions to solve these problems have been proposed such as in [2]. In this paper, we explore those options numerically and, additionally, show numerical analysis for our proposed design.

2. Materials and Methods

In this article, mu-metal and steel have been used for shielding, and the software which is used for calculations and simulations is CST-2019, static and low-frequency modes, and LF frequency domain. Simulated models for analysed cases had 113483,150236,456103,280494 and 38022 mesh cell, respectively; defined required maximum relative error was $1e-3$ with minimum two and maximum ten steps of mesh refinement. Open boundary conditions have been considered. The boundary condition defines the radiating environment of the model. If you specify open, the simulator effectively places perfectly matched microwave absorber material at the boundary, which guarantees that this plane appears to be open space. The applied field has a constant value in all directions (51.5A/m). The *matchbox* design consists of two boxes that will fit inside each other, and each box consists of specific turns of mu-metal with 0.01-inch thickness. Third type of shielding was initially designed by M. R. Hernández which is similar to matchbox [4] as shown in Figure 1(a). We explore several modifications of this initial design in our work, with different wall-thickness parameters.

Our proposed design is based on magnetic field minimization in the shield interior with minimum cost; since high thickness mu-metal is rather expensive.

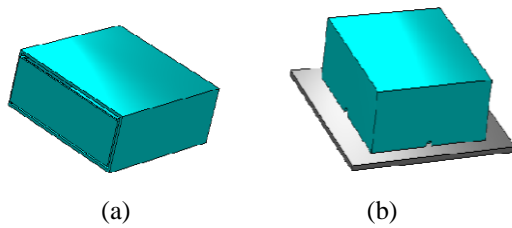

Figure 1. (a) Matchbox design (b) Proposed design

To achieve this, we used a mu-metal box with a thickness of 0.01 inch placed like a tray-cap on one layer of steel with a thickness of 0.5 cm. In order to adjust the humidity and flow of CO₂ between inside and outside of the box, several holes (circle of radius 0.5cm) have been placed in this design (Figure 1 (b)). In all cases, the relative magnetic field intensity in the center of the interior is given by Equation (1):

$$\text{Evaluated relative magnetic field intensity} = \frac{\text{Maximum EM field in the middle of the designed shield}}{\text{Applied EM field}} \quad (1)$$

3. Results

Overall, five different cases are simulated, and results are described below:

Case 1: This shield is constructed from two separate boxes that fit inside each other like a matchbox. The walls are made from 0.12-inch mu-metal. Relative field intensity for 50 Hz, 30 Hz, and 5 Hz EM field are 0.0023, 0.0021, and 0.0019, respectively. Figure 2 shows the maximum EM field for 3 different frequencies in the presence of mentioned designed shield (2) (matchbox) with doubled layers.

Case 2: This design is constructed from two separate boxes that fit into each other like a matchbox with walls made from 0.06-inch mu-metal. Obtained relative field intensities for 50 Hz, 30 Hz, and 5 Hz EM field are 0.48, 0.38, and 0.87, respectively. Figure 3 shows the maximum EM field for 3 different frequencies in the presence of the modified shield (2) (matchbox).

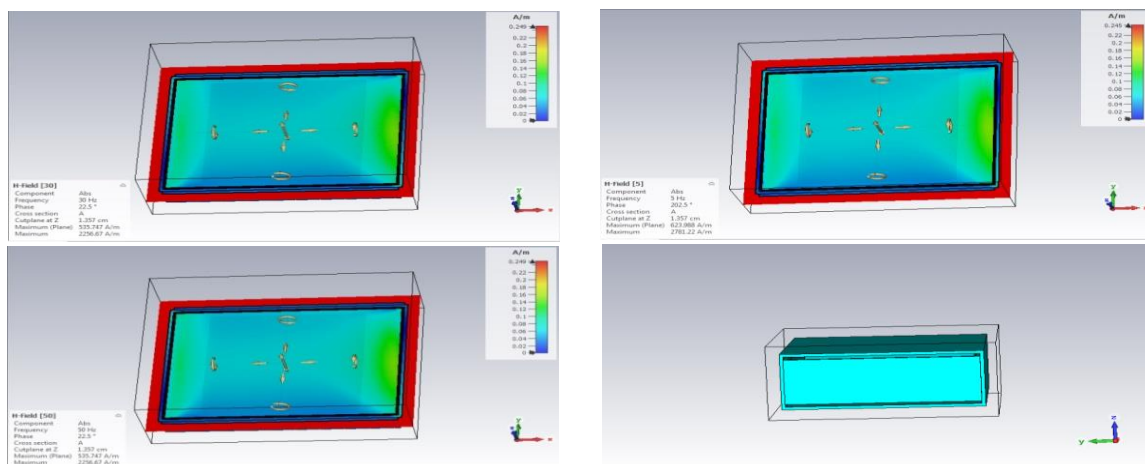

Figure 2. EM fields in (a) 5Hz (b) 30Hz (c) 50Hz frequencies, and (d) the shape of designed shield

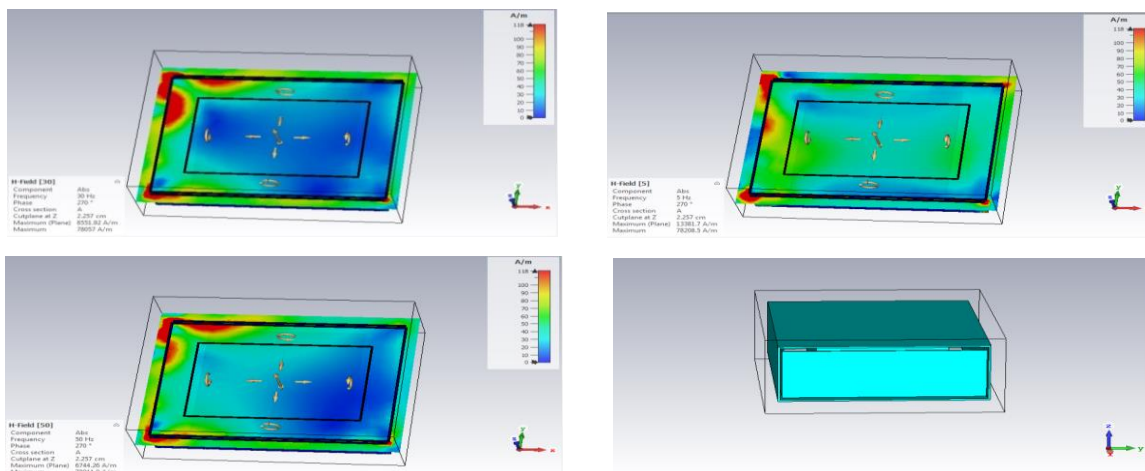

Figure 3. EM field permeability in (a) 5Hz (b) 30Hz (c) 50Hz, and (d) the shape of designed

Case 3: in this case iron is used instead of mu-metal in designed shields (2) (matchbox). Obtained relative field intensities for 50 Hz, 30 Hz, and 5 Hz EM field are 0.65, 0.67, and 1.35, respectively.

Figure 4 shows the maximum EM field for 3 different frequencies in the presence of the designed shield (2) (matchbox) by using iron instead of mu-metal.

Case 4: In this case a completely closed box constructed made from mu-metal with 0.01-inch thickness has been used (Figure 5). Obtained relative field intensities for 50 Hz, 30 Hz, and 5 Hz EM field are 0.077, 0.054, and 0.027, respectively. Please note that this case is not realizable in practice because of blocking CO2 entry, and has only been included for comparison.

Case 5: In this case the box is constructed of mu-metal with 0.01-inch thickness and 1-cm diameter holes around it and one side of the box is open. A sheet of steel with 0.5-cm thickness covers the open side

(proposed design) (Figure 6). Obtained relative field intensities for 50 Hz, 30 Hz, and 5 Hz EM field are 0.038, 0.032, and 0.029, respectively.

Table 1 shows the evaluated relative magnetic field intensities for all five cases in three different frequencies according to Equation (1).

4. Discussion and Conclusion

As shown in Table 1, the proposed design (case 5) satisfies appropriate protection (remaining field below 5%) for cells in incubators with much cheaper design than other designs because of the mu-metal used in construction.

Although case 1 shows superior attenuation, it is too expensive because it is made of 6 layers of mu-metal for the walls, whereas in case 5 we can achieve reasonable attenuation with lower price.

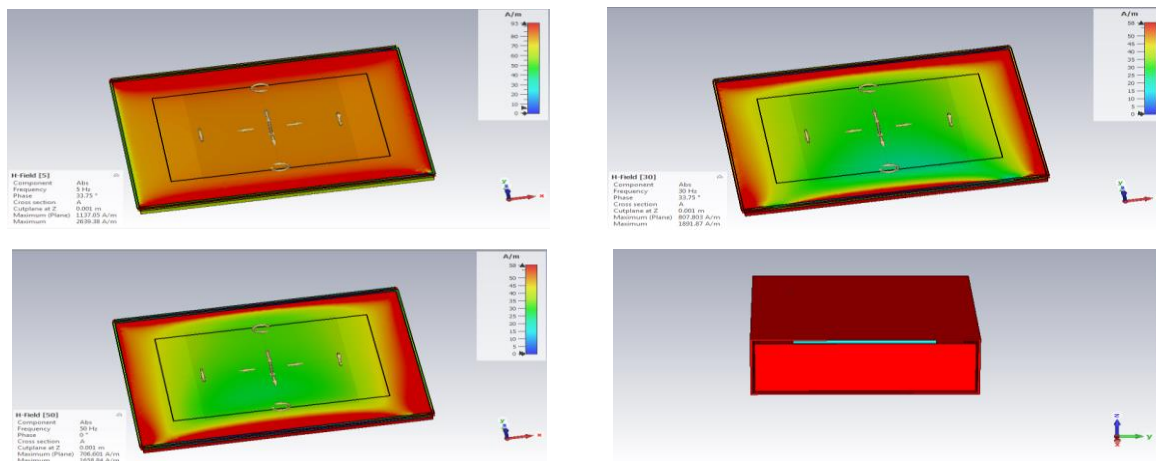

Figure 4. EM fields permeability in (a) 5Hz (b) 30Hz (c) 50Hz, and (d) the shape of designed shield

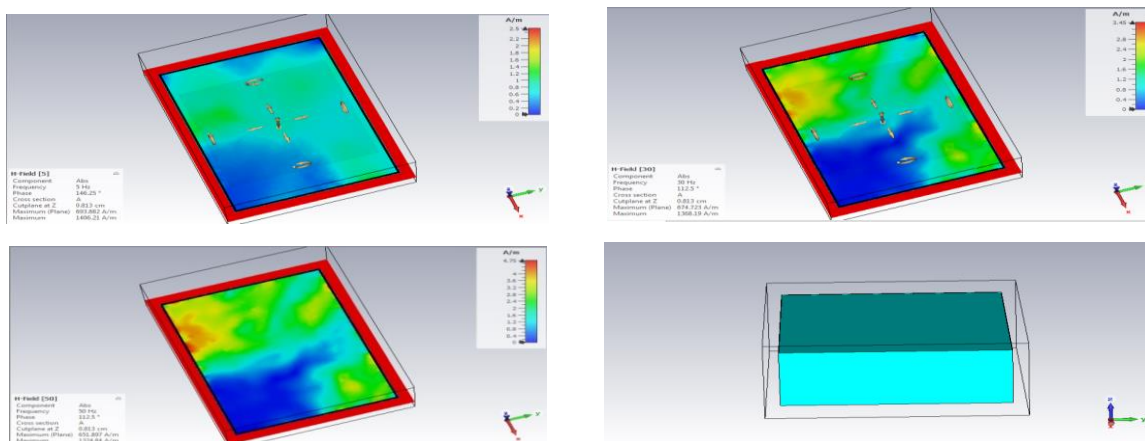

Figure 5. EM field permeability in (a) 5Hz (b) 30Hz (c) 50Hz, and (d) the shape of designed shield

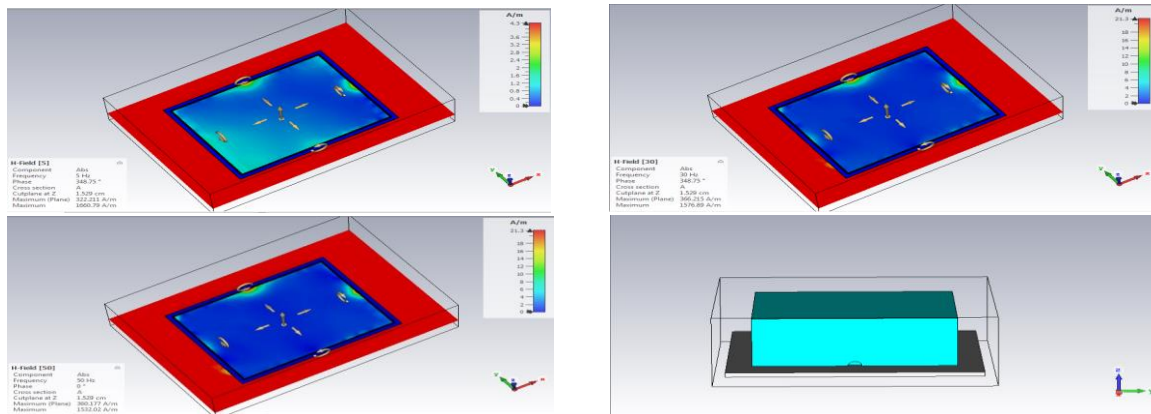

Figure 6. EM field permeability in (a) 5Hz (b) 30Hz (c) 50Hz, and (d) the shape of designed shield

Table 1. Evaluated relative magnetic field intensity

	5 HZ	30 HZ	50 HZ
First case	0.0019	0.0021	0.0023
Second case	0.87	0.38	0.48
Third case	1.35	0.67	0.65
Fourth case	0.027	0.054	0.077
Fifth case	0.029	0.032	0.038

References

- 1- L. A. Portelli, K. Falldorf, G. Thuróczy, and J. Cuppen, "Retrospective estimation of the electric and magnetic field exposure conditions in in vitro experimental reports reveal considerable potential for uncertainty," (in eng), *Bioelectromagnetics*, vol. 39, no. 3, pp. 231-243, Apr 2018, doi: 10.1002/bem.22099.
- 2- L. A. Portelli, T. E. Schomay, and F. S. Barnes, "Inhomogeneous background magnetic field in biological incubators is a potential confounder for experimental variability and reproducibility", (in eng), *Bioelectromagnetics*, vol. 34, no. 5, pp. 337-48, Jul 2013, doi: 10.1002/bem.21787.
- 3- I. Gresits, P. P. Necz, G. Jánossy, and G. Thuróczy, "Extremely low frequency (ELF) stray magnetic fields of laboratory equipment: a possible co-exposure conducting experiments on cell cultures," (in eng), *Electromagn Biol Med*, vol. 34, no. 3, pp. 244-50, Sep 2015, doi: 10.3109/15368378.2015.1076440.
- 4- M. Reta-Hernández and G. G. Karady, "Attenuation of low frequency magnetic fields using active shielding", *Electric power systems research*, vol. 45, no. 1, pp. 57-63, 1998.
- 5- J. Malmivuo, J. Lekkala, P. Kontro, L. Suomaa, and H. Vihinen, "Improvement of the properties of an eddy current magnetic shield with active compensation," *Journal of Physics E: Scientific Instruments*, vol. 20, no. 2, p. 151, 1987.
- 6- W. R. Bennett, *Health and low-frequency electromagnetic fields*. Yale University Press New Haven, CT, 1994.
- 7- L. Cellini *et al.*, "Bacterial response to the exposure of 50 Hz electromagnetic fields," (in eng), *Bioelectromagnetics*, vol. 29, no. 4, pp. 302-11, May 2008, doi: 10.1002/bem.20391.
- 8- R. Gaetani *et al.*, "Differentiation of human adult cardiac stem cells exposed to extremely low-frequency electromagnetic fields," (in eng), *Cardiovasc Res*, vol. 82, no. 3, pp. 411-20, Jun 2009, doi: 10.1093/cvr/cvp067.
- 9- A. Cossarizza *et al.*, "Exposure to low-frequency pulsed electromagnetic fields increases mitogen-induced lymphocyte proliferation in Down's syndrome," *Aging Clinical and Experimental Research*, vol. 3, no. 3, pp. 241-246, 1991.
- 10- A. Cossarizza *et al.*, "Extremely low frequency pulsed electromagnetic fields increase cell proliferation in lymphocytes from young and aged subjects," *Biochemical and biophysical research communications*, vol. 160, no. 2, pp. 692-698, 1989.
- 11- R. Cadossi *et al.*, "Lymphocytes and low-frequency electromagnetic fields," *The FASEB journal*, vol. 6, no. 9, pp. 2667-2674, 1992.
- 12- A. Cossarizza *et al.*, "Exposure to low frequency pulsed electromagnetic fields increases interleukin-1 and interleukin-6 production by human peripheral blood mononuclear cells," *Experimental cell research*, vol. 204, no. 2, pp. 385-387, 1993.

- 13- A. Lisi *et al.*, "Extremely low frequency electromagnetic field exposure promotes differentiation of pituitary corticotrope-derived AtT20 D16V cells," (in eng), *Bioelectromagnetics*, vol. 27, no. 8, pp. 641-51, Dec 2006, doi: 10.1002/bem.20255.
- 14- A. Basile *et al.*, "Exposure to 50 Hz electromagnetic field raises the levels of the anti-apoptotic protein BAG3 in melanoma cells," (in eng), *J Cell Physiol*, vol. 226, no. 11, pp. 2901-7, Nov 2011, doi: 10.1002/jcp.22641.
- 15- B. J. Patton and J. L. Fitch, "Design of a room-size magnetic shield," *Journal of Geophysical Research*, vol. 67, no. 3, pp. 1117-112 ,1962.
- 16- H. Brake, H. Wieringa, and H. Rogalla, "Improvement of the performance of a mu -metal magnetically shielded room by means of active compensation (biomagnetic applications)," *Measurement Science and Technology*, vol. 2, p. 596, 01/01 1999.